

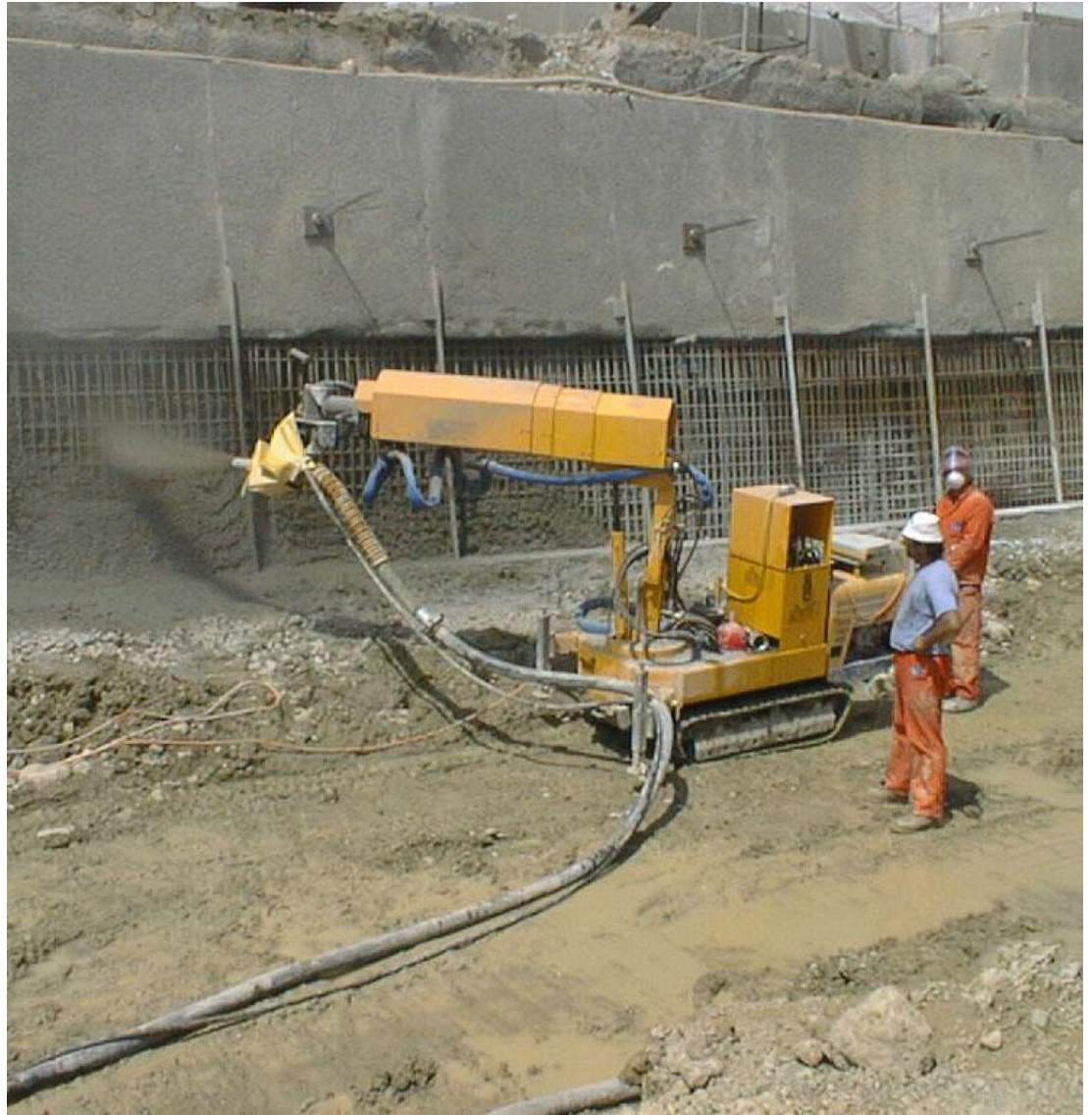

AL-503 Mini concrete spraying system



For mining and small tunnels
Modular concept
Air, electric, diesel driven
Very flexible concrete spraying

Dimensions:

Transport length:	~ 2.3 m
Transport width:	~ 1.2 m
Transport height:	~ 2.1 m
Weight:	~ 1,900 kg
Rotating radius:	1.9 m
Ground clearance:	130 mm
Outriggers:	2.7 m
Max. spraying height:	8 m
Max. Length:	7 m
Min. Length:	2 m
Stroke arm:	3 m
Spraying angle:	240 °
Nozzle angle:	360 °
Remote control:	electric (cable 15m)

Drive:

Gears:	4 / 3 forw / rev
Speed min.:	1,6 km/h
Speed max.:	7,4 km/h

Diesel motor:

Motor output:	7 kW (9,5 HP)
Volume:	443 cm ³
Cooling:	water

Air motor:

Motor output:	7,5 kW (10 HP)
Air pressure:	4,4 bar
Air consumption:	10 m ³ /min

Technical Data

The mini concrete spraying system AL-503 is a handy mechanized concrete spraying tool, especially designed for mines, small stopes and pits.

The unit consists of the telescope spraying arm AL-302 mounted on a tracked carrier.

For flame proof operation the diesel motor of the carrier is replaced by an air motor.

Working range

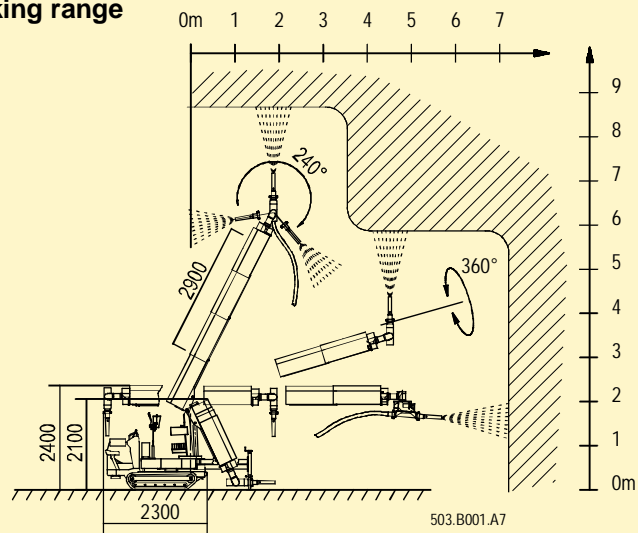

Hydraulic unit:

Electric motor

Air motor

Oil pressure:	210 bar	210 bar
Oil quantity:	28 l/min	23 l/min
Motor output:	7,5 kW	Air motor from carrier

Technical and design modifications remain reserved at all times. Technical properties have been achieved under theoretical and normal conditions. Please consult the respective machine manual for all matters related to operations and maintenance.

For us a matter of principle



Sika Schweiz AG

Aliva Equipment CH-8048 Zürich / Switzerland

Phone ++ 41 58 436 4040

www.sika.com

Fax ++ 41 58 436 4140 aliva_equipment@ch.sika.com

Your local dealer



Rock Solid Solutions

Authorized Distributor:

Thiessen Team USA
1840 Sharps Access Rd
Elko, NV 89801
Ph: (775) 777-1205 Fax: (775) 777-1215
www.thiessenteam.com